

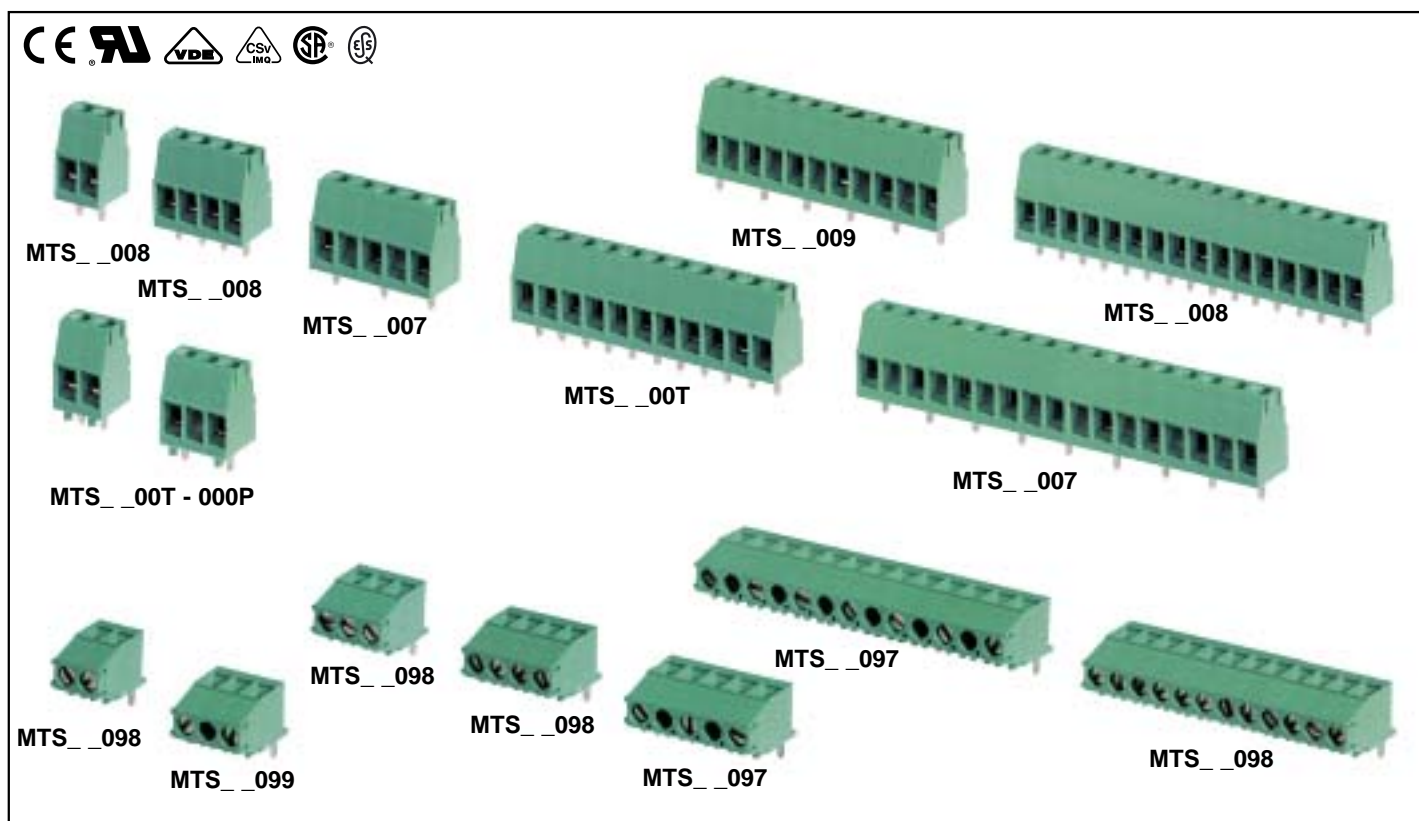

Dimensional Class: LOW
Standard Color: GREEN
Height: .496 in (12.6 mm) Straight - .323 in (8.2 mm) 90°
Clamp Opening Size: .102 x .067 in (2.6 x 1.7 mm)
Wire Diameter: max. .067 in (2.27 mm²)
Versions: Modular with Dovetails
Single Mold Poles: from 2 to 25
Metric Pitches: .138 in (3.5 mm), .275 in (7 mm)
Imperial Pitches: .150 in (3.81 mm), .300 in (7.62 mm)

Classe Dimensionale: BASSA
Colore Standard: VERDE
Altezza: 12,6 mm Diritto - 8,2 mm 90°
Apertura Introduzione Filo: 2,6 x 1,7 mm
Diametro Filo Inseribile: max. 1,7 mm (2,27 mm²)
Versioni: Modulare con incastro a coda di rondine
Vie Monolitiche: da 2 a 25
Passi Metrici: 3,5 mm, 7 mm
Passi in Pollici: 3,81 mm, 7,62 mm



The modular MTS terminal block Series for printed circuit boards satisfies the user's mounting needs with the following possibilities:

- using individual single mold terminal blocks from 2 to 25 poles;
- combining single mold terminal blocks from 2 to 25 poles to obtain any number of poles; all MTS products, including single mold versions, have dovetail capabilities;
- minimizing the stock by storing only some base terminal blocks (ex. 2, 3... 25 poles) to enable combinations described above;
- being included in a custom Kit package to simplify the product management (part-numbers reduction), to minimize the stock, to improve the assembly and to reduce production errors.

MTS with Pegs

The Straight 2 poles MTS is also available with clamping pegs molded in the plastic housing to secure it to the board.

This solution increases the connector tightening torque and allows it to pass the most restrictive guidelines set by international standards.

La morsettiere modulare Serie MTS per circuiti stampati soddisfa le esigenze di montaggio dell'utilizzatore; infatti è possibile:

- utilizzare singolarmente le morsettiere base monolitiche da 2 a 25 vie;
- comporre le morsettiere base monolitiche da 2 a 25 vie per ottenere qualsiasi numero di vie;
- gestire uno stoccaggio minimo di morsettiere base (es. 2 - 3... 25 vie) per ottenere quanto sopra;
- utilizzare le confezioni Kit che permettono una semplificazione della gestione del prodotto (riduzione dei part-number), del magazzino, dell'assemblaggio, nonché una riduzione dei rischi d'errore.

MTS con Piolini

La morsettiere MTS 2 vie Diritta è disponibile anche con piolini di ancoraggio a scheda, integrati nel corpo plastico.

Questa soluzione consente di scaricare la coppia di serraggio a scheda e di superare le prescrizioni più restrittive richieste da alcune normative internazionali.

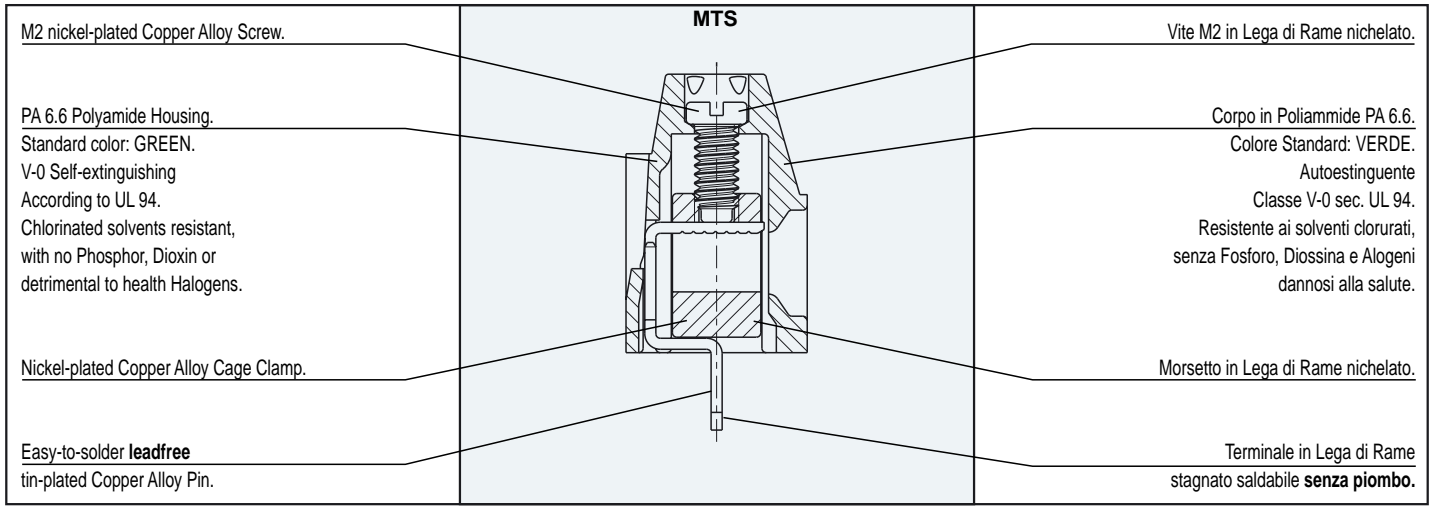

Mechanical Characteristics

Recommended tightening torque:	0.25 Nm (UL)*
PCB thickness:	max. .094 in (max. 2.4 mm)
PCB hole diameter:	min. .043 (min. 1.1 mm)
Stripping length:	.20 ÷ .24 in (5 ÷ 6 mm)
Operating temperature range:	-40 °F ÷ +230 °F (-40 °C ÷ +110 °C)
Climatic category:	40/110/21 According IEC 68-1

Electrical Characteristics

Solid wire section:	30÷14 AWG - 0.05÷1.5 mm ² (UL, CSA)*
Stranded wire section:	30÷14 AWG - 0.05÷1 mm ² (UL, CSA)*
Rated voltage:	.138 in (3.5 mm) and .150 in (3.81 mm) pitch 300 V (UL, CSA)* .275 in (7 mm) and .300 in (7.62 mm) pitch 750 V (IMQ)*
Rated current:	17.5 A (IMQ)*
Contact resistance:	<15 mΩ
Insulation resistance:	>10 ⁹ Ω (500V DC)

*All the a.m. data refer to the highest values amongst the certificated ones (). **V** voltage, **I** current values and tightening torque are related to the norms to be applied to the product and to its use.

Caratteristiche Meccaniche

Coppia di serraggio consigliata:	0,25 Nm (UL)*
Spessore circuito stampato:	max. 2,4 mm
Diametro fori circuito stampato:	min. 1,1 mm
Lunghezza di spellatura:	5 ÷ 6 mm
Temperature di funzionamento:	-40 °C ÷ +110 °C
Categoria climatica:	40/110/21 Secondo IEC 68-1

Caratteristiche Elettriche

Conduttore connettabile rigido:	0,05÷1,5 mm ² - 30÷14 AWG (UL, CSA)*
Conduttore connettabile flessibile:	0,05÷1 mm ² - 30÷14 AWG (UL, CSA)*
Tensione nominale:	passo 3,5 mm e 3,81 mm 300 V (UL, CSA)* passo 7 mm e 7,62 mm 750 V (IMQ)*
Corrente nominale:	17,5 A (IMQ)*
Resistenza di contatto:	<15 mΩ
Resistenza di isolamento:	>10 ⁹ Ω (500V CC)

*Per ogni caratteristica, i dati riportati si riferiscono ai massimi valori fra quelli certificati (). I valori di tensione **V** corrente **I** e, coppia di serraggio sono legati alle norme applicabili al prodotto ed al tipo di utilizzo.

Approvals

(see also "Certifications", page 22)

VDE:	Reg. N. 134879 ÜG
	130 V - 12 A - T 110 - 1 mm ² for 3.5 mm and 3.81 mm pitch 450 V - 12 A - T 110 - 1 mm ² for 7 mm and 7.62 mm pitch Test torque 0.25 Nm

IMQ:	Certificate with Surveillance IMQ CSv CA02.00146
ESS:	130 V - T 110 - 17.5 A - 1.5 mm ² solid (12 A - 1 mm ² stranded) for 3.5 mm and 3.81 mm pitch 750 V - T 110 - 17.5 A - 1.5 mm ² solid (12 A - 1 mm ² stranded) for 7 mm and 7.62 mm pitch Test torque 0.25 Nm

CSA:	File LR 102896-1
	300 V - 12 A - 30÷14 AWG for 3.5 mm and 3.81 mm pitch 450 V - 12 A - 30÷14 AWG for 7 mm and 7.62 mm pitch

UL:	File E 167473
	300 V - 12 A - 30÷14 AWG for 3.5 mm, 3.81 mm pitch, 7 mm and 7.62 mm pitch Application values for end-use equipment have to be in accordance to UL norms and applicable to it.

Certificazioni

(vedi anche "Certificazioni", pag. 22)



VDE:	Reg. N. 134879 ÜG
	130 V - 12 A - T 110 - 1 mm ² per passo 3,5 mm e 3,81 mm 450 V - 12 A - T 110 - 1 mm ² per passo 7 mm e 7,62 mm Coppia di prova 0,25 Nm



IMQ:	Certificato con Sorveglianza IMQ CSv CA02.00146
ESS:	130 V - T 110 - 17,5 A - 1,5 mm ² rigido (12 A - 1 mm ² flessibile) per passo 3,5 mm e 3,81 mm 750 V - T 110 - 17,5 A - 1,5 mm ² rigido (12 A - 1 mm ² flessibile) per passo 7 mm e 7,62 mm Coppia di prova 0,25 Nm



CSA:	File LR 102896-1
	300 V - 12 A - 30÷14 AWG per passo 3,5 mm e 3,81 mm 450 V - 12 A - 30÷14 AWG per passo 7 mm e 7,62 mm



UL:	File E 167473
	300 V - 12 A - 30÷14 AWG per passo 3,5 mm, 3,81 mm, 7 mm e 7,62 mm I valori di utilizzo per l'apparecchiatura finale devono essere conformi alle norme UL ad essa applicabili.

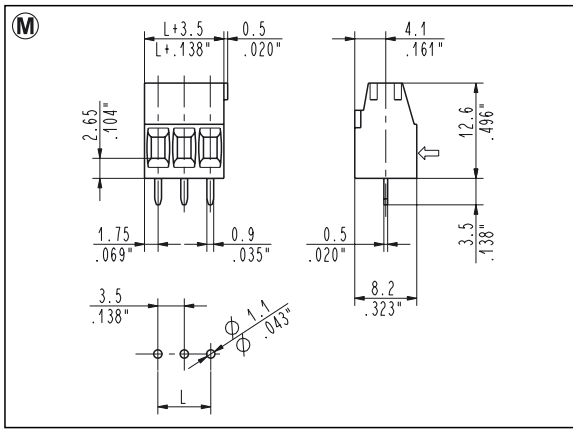

MTS_008 Straight, Side Entry
3.5 mm / .138" Pitch Weight per pole: 0.81 g

Poles	STD Code	L [mm]	L [inch]	Pcs/pack.	W [kg]
02	MTS02008	3.50	0.138	800	1.30
03	MTS03008	7.00	0.276	500	1.22
04	MTS04008	10.50	0.413	400	1.30
05	MTS05008	14.00	0.551	300	1.22
06	MTS06008	17.50	0.689	250	1.22
07	MTS07008	21.00	0.827	200	1.14
08	MTS08008	24.50	0.965	175	1.14
09	MTS09008	28.00	1.102	150	1.10
10	MTS10008	31.50	1.240	125	1.01
11	MTS11008	35.00	1.378	125	1.12
12	MTS12008	38.50	1.516	100	0.97
13	MTS13008	42.00	1.654	150	1.05
14	MTS14008	45.50	1.791	150	1.14
15	MTS15008	49.00	1.929	150	1.22
16	MTS16008	52.50	2.067	150	1.30
17	MTS17008	56.00	2.205	100	1.38
18	MTS18008	59.50	2.343	100	1.46
19	MTS19008	63.00	2.480	100	1.54
20	MTS20008	66.50	2.618	100	1.62
21	MTS21008	70.00	2.756	100	1.70
22	MTS22008	73.50	2.894	100	1.78
23	MTS23008	77.00	3.031	100	1.87
24	MTS24008	80.50	3.169	100	1.95
25	MTS25008	84.00	3.307	75	2.03

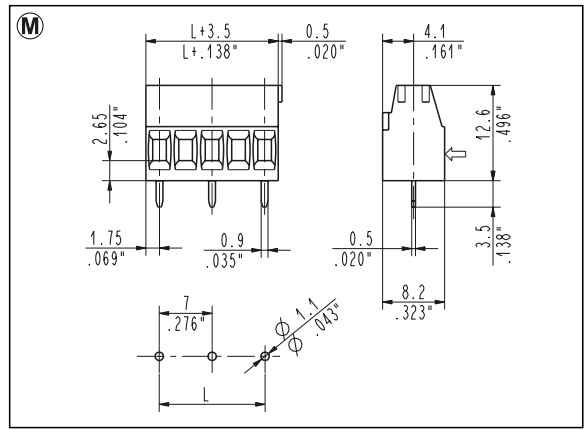

MTS_009 Straight, Side Entry
7 mm / .275" Pitch Weight per pole: 0.94 g

Poles	STD Code	L [mm]	L [inch]	Pcs/pack.	W [kg]
02	MTS02009	7.00	0.276	500	0.94
03	MTS03009	14.00	0.551	300	0.84
04	MTS04009	21.00	0.827	200	0.75
05	MTS05009	28.00	1.102	150	0.70
06	MTS06009	35.00	1.378	125	0.70
07	MTS07009	42.00	1.654	150	0.66
08	MTS08009	49.00	1.929	150	0.75
09	MTS09009	56.00	2.205	100	0.84
10	MTS10009	63.00	2.480	100	0.94
11	MTS11009	70.00	2.756	100	1.03
12	MTS12009	77.00	3.031	100	1.12
13	MTS13009	84.00	3.307	75	1.22

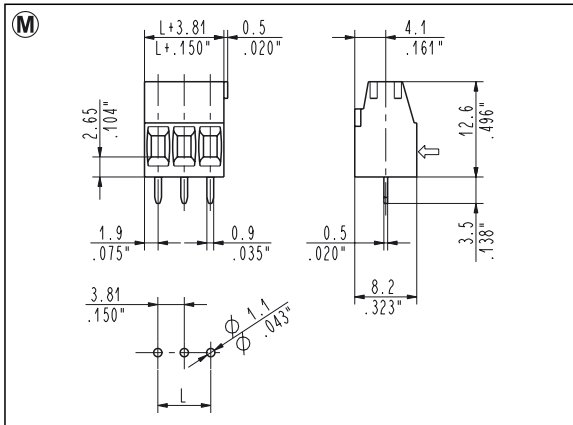

MTS_00T Straight, Side Entry
3.81 mm / .150" Pitch Weight per pole: 0.81 g

Poles	STD Code	L [mm]	L [inch]	Pcs/pack.	W [kg]
02	MTS0200T	3.81	0.150	800	1.30
03	MTS0300T	7.62	0.300	500	1.22
04	MTS0400T	11.43	0.450	400	1.30
05	MTS0500T	15.24	0.600	300	1.22
06	MTS0600T	19.05	0.750	250	1.22
07	MTS0700T	22.86	0.900	200	1.14
08	MTS0800T	26.67	1.050	175	1.14
09	MTS0900T	30.48	1.200	150	1.10
10	MTS1000T	34.29	1.350	125	1.01
11	MTS1100T	38.10	1.500	125	1.12
12	MTS1200T	41.91	1.650	100	0.97
13	MTS1300T	45.72	1.800	150	1.05
14	MTS1400T	49.53	1.950	150	1.14
15	MTS1500T	53.34	2.100	150	1.22
16	MTS1600T	57.15	2.250	150	1.30
17	MTS1700T	60.96	2.400	100	1.38
18	MTS1800T	64.77	2.550	100	1.46
19	MTS1900T	68.58	2.700	100	1.54
20	MTS2000T	72.39	2.850	100	1.62
21	MTS2100T	76.20	3.000	100	1.70
22	MTS2200T	80.01	3.150	100	1.78
23	MTS2300T	83.82	3.300	100	1.87
24	MTS2400T	87.63	3.450	100	1.95
25	MTS2500T	91.44	3.600	75	2.03

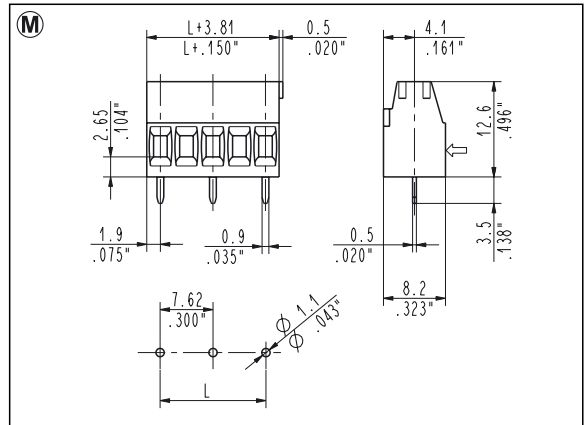

MTS_007 Straight, Side Entry
7.62 mm / .300" Pitch Weight per pole: 0.94 g

Poles	STD Code	L [mm]	L [inch]	Pcs/pack.	W [kg]
02	MTS02007	7.62	0.300	500	0.94
03	MTS03007	15.24	0.600	300	0.84
04	MTS04007	22.86	0.900	200	0.75
05	MTS05007	30.48	1.200	150	0.70
06	MTS06007	38.10	1.500	125	0.70
07	MTS07007	45.72	1.800	150	0.66
08	MTS08007	53.34	2.100	150	0.75
09	MTS09007	60.96	2.400	100	0.84
10	MTS10007	68.58	2.700	100	0.94
11	MTS11007	76.20	3.000	100	1.03
12	MTS12007	83.82	3.300	100	1.12
13	MTS13007	91.44	3.600	75	1.22

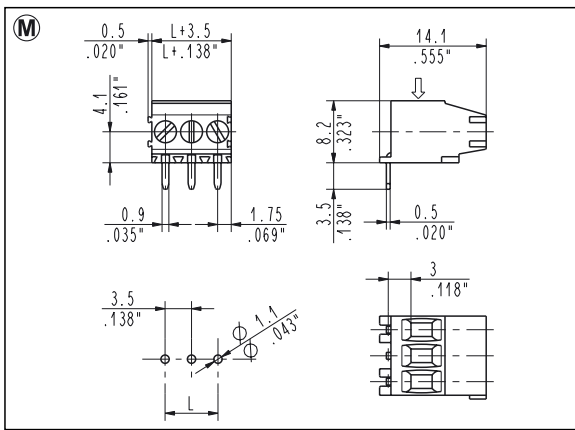

MTS_098 90°, Top Entry
3.5 mm / .138" Pitch Weight per pole: 0.81 g

Poles	STD Code	L [mm]	L [inch]	Pcs/pack.	W [kg]
02	MTS02098	3.50	0.138	800	1.30
03	MTS03098	7.00	0.276	500	1.22
04	MTS04098	10.50	0.413	400	1.30
05	MTS05098	14.00	0.551	300	1.22
06	MTS06098	17.50	0.689	250	1.22
07	MTS07098	21.00	0.827	200	1.14
08	MTS08098	24.50	0.965	175	1.14
09	MTS09098	28.00	1.102	150	1.10
10	MTS10098	31.50	1.240	125	1.01
11	MTS11098	35.00	1.378	125	1.12
12	MTS12098	38.50	1.516	100	0.97
13	MTS13098	42.00	1.654	150	1.05
14	MTS14098	45.50	1.791	150	1.14
15	MTS15098	49.00	1.929	150	1.22
16	MTS16098	52.50	2.067	150	1.30
17	MTS17098	56.00	2.205	100	1.38
18	MTS18098	59.50	2.343	100	1.46
19	MTS19098	63.00	2.480	100	1.54
20	MTS20098	66.50	2.618	100	1.62
21	MTS21098	70.00	2.756	100	1.70
22	MTS22098	73.50	2.894	100	1.78
23	MTS23098	77.00	3.031	100	1.87
24	MTS24098	80.50	3.169	100	1.95
25	MTS25098	84.00	3.307	75	2.03

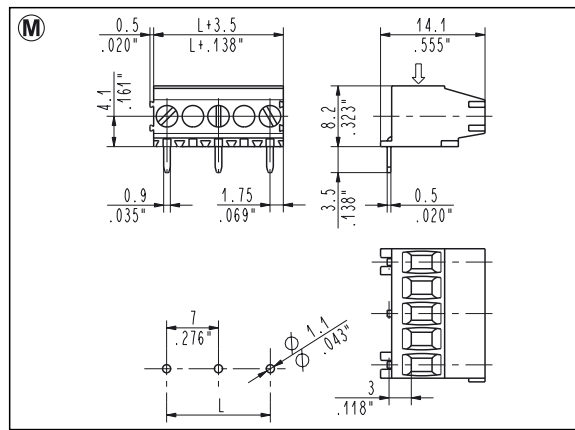

MTS_099 90°, Top Entry
7 mm / .275" Pitch Weight per pole: 0.94 g

Poles	STD Code	L [mm]	L [inch]	Pcs/pack.	W [kg]
02	MTS02099	7.00	0.276	500	0.94
03	MTS03099	14.00	0.551	300	0.84
04	MTS04099	21.00	0.827	200	0.75
05	MTS05099	28.00	1.102	150	0.70
06	MTS06099	35.00	1.378	125	0.70
07	MTS07099	42.00	1.654	150	0.66
08	MTS08099	49.00	1.929	150	0.75
09	MTS09099	56.00	2.205	100	0.84
10	MTS10099	63.00	2.480	100	0.94
11	MTS11099	70.00	2.756	100	1.03
12	MTS12099	77.00	3.031	100	1.12
13	MTS13099	84.00	3.307	75	1.22

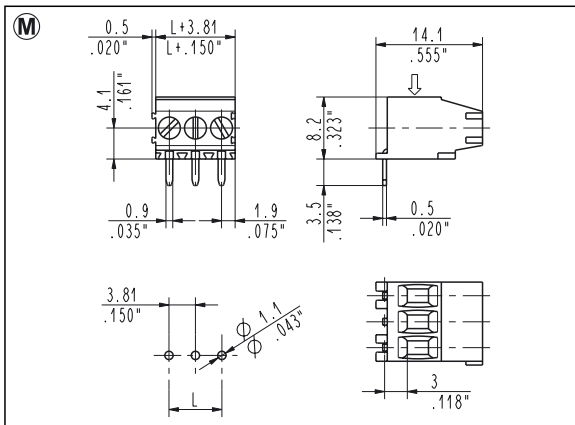

MTS_09T 90°, Top Entry
3.81 mm / .150" Pitch Weight per pole: 0.81 g

Poles	STD Code	L [mm]	L [inch]	Pcs/pack.	W [kg]
02	MTS0209T	3.81	0.150	800	1.30
03	MTS0309T	7.62	0.300	500	1.22
04	MTS0409T	11.43	0.450	400	1.30
05	MTS0509T	15.24	0.600	300	1.22
06	MTS0609T	19.05	0.750	250	1.22
07	MTS0709T	22.86	0.900	200	1.14
08	MTS0809T	26.67	1.050	175	1.14
09	MTS0909T	30.48	1.200	150	1.10
10	MTS1009T	34.29	1.350	125	1.01
11	MTS1109T	38.10	1.500	125	1.12
12	MTS1209T	41.91	1.650	100	0.97
13	MTS1309T	45.72	1.800	150	1.05
14	MTS1409T	49.53	1.950	150	1.14
15	MTS1509T	53.34	2.100	150	1.22
16	MTS1609T	57.15	2.250	150	1.30
17	MTS1709T	60.96	2.400	100	1.38
18	MTS1809T	64.77	2.550	100	1.46
19	MTS1909T	68.58	2.700	100	1.54
20	MTS2009T	72.39	2.850	100	1.62
21	MTS2109T	76.20	3.000	100	1.70
22	MTS2209T	80.01	3.150	100	1.78
23	MTS2309T	83.82	3.300	100	1.87
24	MTS2409T	87.63	3.450	100	1.95
25	MTS2509T	91.44	3.600	75	2.03

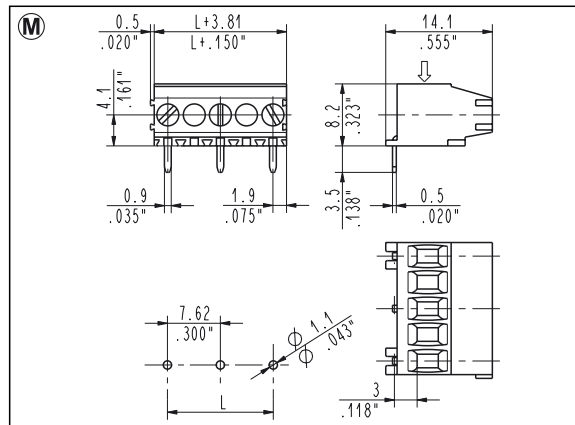

MTS_097 90°, Top Entry
7.62 mm / .300" Pitch Weight per pole: 0.94 g

Poles	STD Code	L [mm]	L [inch]	Pcs/pack.	W [kg]
02	MTS02097	7.62	0.300	500	0.94
03	MTS03097	15.24	0.600	300	0.84
04	MTS04097	22.86	0.900	200	0.75
05	MTS05097	30.48	1.200	150	0.70
06	MTS06097	38.10	1.500	125	0.70
07	MTS07097	45.72	1.800	150	0.66
08	MTS08097	53.34	2.100	150	0.75
09	MTS09097	60.96	2.400	100	0.84
10	MTS10097	68.58	2.700	100	0.94
11	MTS11097	76.20	3.000	100	1.03
12	MTS12097	83.82	3.300	100	1.12
13	MTS13097	91.44	3.600	75	1.22

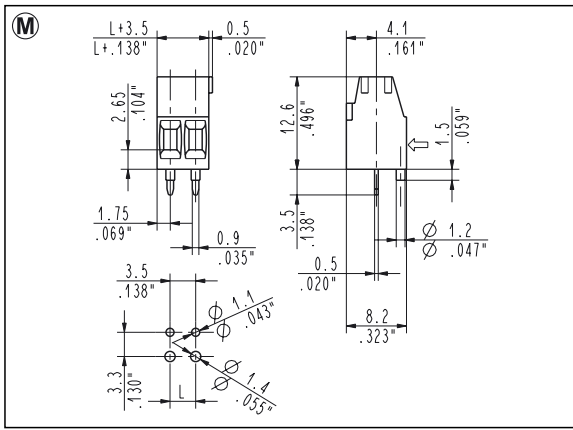

MTS02008 - 0000P Straight with Vde Pegs, Side Entry
3.5 mm / .138" Pitch Weight per pole: 0.81 g

Poles	STD Code	L [mm]	L [inch]	Pcs/pack.	W [kg]
02	MTS02008-0000P	3.50	0.138	800	1.30

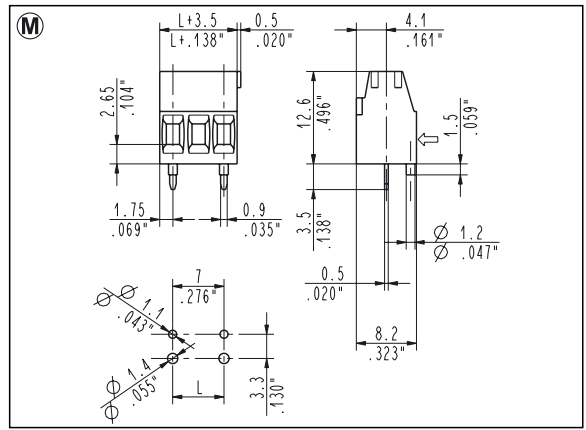

MTS02009 - 0000P Straight with Vde Pegs, Side Entry
7 mm / .275" Pitch Weight per pole: 0.94 g

Poles	STD Code	L [mm]	L [inch]	Pcs/pack.	W [kg]
02	MTS02009-0000P	7.00	0.276	500	0.94

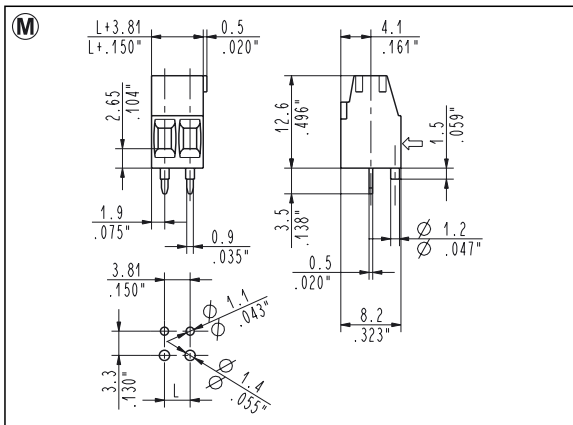

MTS0200T - 0000P Straight with Vde Pegs, Side Entry
3.81 mm / .150" Pitch Weight per pole: 0.81 g

Poles	STD Code	L [mm]	L [inch]	Pcs/pack.	W [kg]
02	MTS0200T-0000P	3.81	0.150	800	1.30

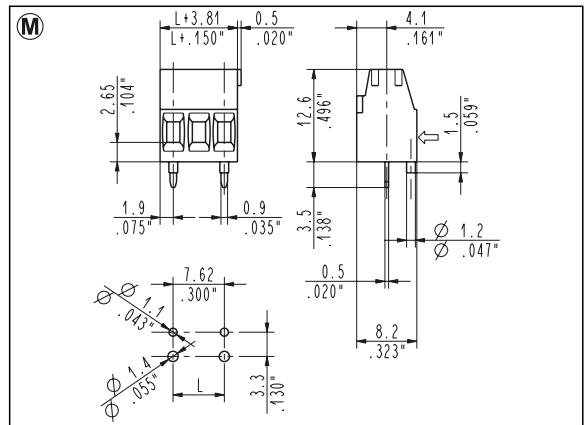

MTS02007 - 0000P Straight with Vde Pegs, Side Entry
7.62 mm / .300" Pitch Weight per pole: 0.94 g

Poles	STD Code	L [mm]	L [inch]	Pcs/pack.	W [kg]
02	MTS02007-0000P	7.62	0.300	500	0.94