

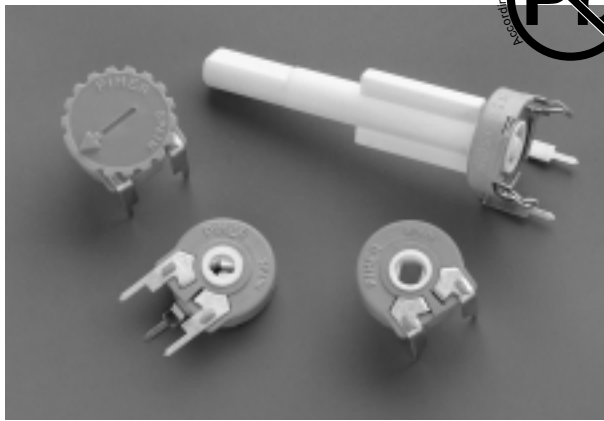

# PTC-15 15 mm Cermet Potentiometer



## FEATURES

- Cermet resistive element
- Dust proof enclosure
- Plastic material according to UL94V-0
- Alumina substrate
- Also upon request:
  - Wiper positioned at 50% or fully clockwise.
  - Long life model for low cost control pot. applications
  - Supplied in magazines for automatic insertion.
  - Low torque option
  - Available as SPDT switch
  - Laser trimming for tighter tolerances
  - Special tapers
  - Mechanical detents

## MECHANICAL SPECIFICATIONS

- Mechanical rotation angle:  $265^\circ \pm 5^\circ$
- Electrical rotation angle:  $250^\circ \pm 20^\circ$
- Torque: 0.5 to 2.5 Ncm. (0.7 to 3.4 in-oz)
- Stop torque: > 10 Ncm. (>14 in-oz)
- Life\*: Up to 10.000 cycles

\* Others upon request

## ELECTRICAL SPECIFICATIONS

- Range of values (\*)  
 $100\Omega \leq R_n \leq 5\text{ M}$  (Decad. 1.0 - 2.0 - 2.2 - 2.5 - 4.7 - 5.0)
  - Tolerance (\*):  $100\Omega \leq R_n \leq 1\text{M}\Omega$  .....  $\pm 20\%$   
 $1\text{M}\Omega < R_n \leq 5\text{M}\Omega$  .....  $\pm 30\%$
  - Max. Voltage: 250 VDC (lin) 125 VDC (no lin)
  - Nominal Power 70°C (158°F) (see power rating curve)  
0.50 W (lin) 0.25 W (no lin)
  - Taper (\*) (Log. & Alog. only  $R_n \geq 1\text{K}$ ) Lin ; Log; Alog.
  - Residual resistance:  $\leq 5 \cdot 10^{-3} R_n$  (2  $\Omega$  min.)
  - Equivalent Noise Resistance:  $\leq 3\% R_n$  (3  $\Omega$  min.)
  - Operating temperature:  $-40^\circ\text{C} + 90^\circ\text{C}$  ( $-40^\circ\text{F} + 194^\circ\text{F}$ )
- (\*) Others upon request

## HOW TO ORDER

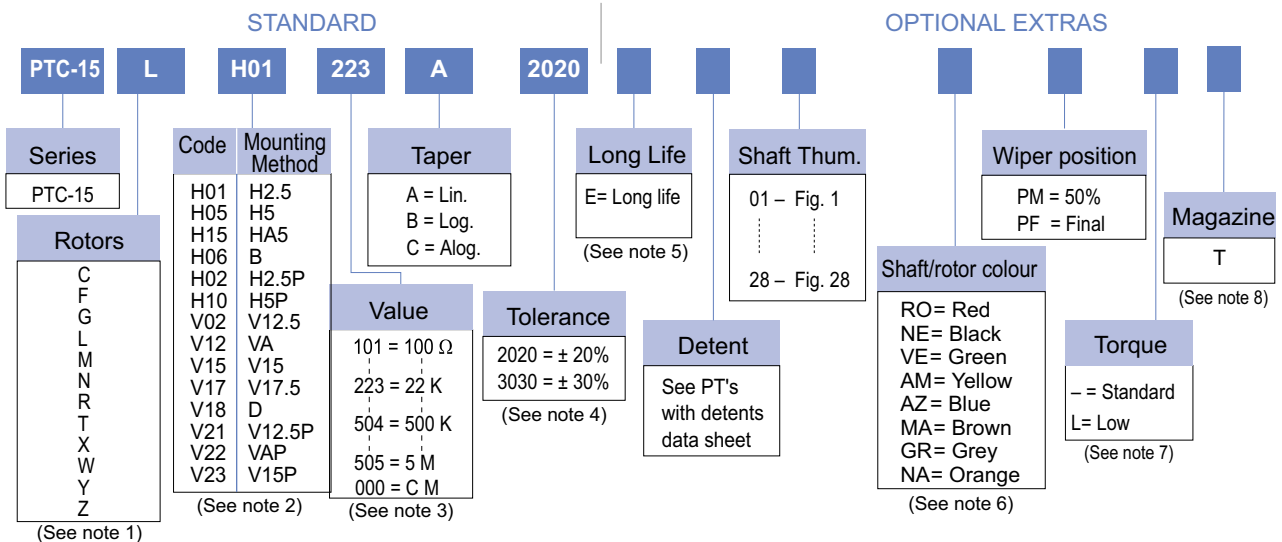

### NOTES:

- "Z" adjustment only available on "H" versions. Standard colour for the "T" rotor: Orange
- Terminals styles: "P" are crimped terminals. V=Vertical adjust; H=Horizontal Adjust
- Value Example: Code:  $\begin{matrix} 10 & 1 & 100\Omega \\ \swarrow & \searrow & \\ \text{Numb of zeros} & \text{First two digits of the value.} & \end{matrix}$   
000 = CM: SPDT switch 45°
- Non standard tolerance, upon request. Example: +7% Code:  $\begin{matrix} 07 & 05 \\ \swarrow & \searrow \\ \text{negative tolerance} & \text{positive tolerance} \end{matrix}$
- Up to 10.000 cycles. Others upon request.
- Colour shaft/rotor:
  - Potentiometer without shaft: only rotor
  - Potentiometer with shaft: only shaft
- Low Torque:  $\leq 1.5\text{Ncm}$ . No detent option available for low torque models
- Magazines (35 pcs/mag): available for VA (12.5), V (12.5), V (12.5P), V (15), V15 (P) and H models. For more information please contact your nearest Piher supplier.

NOTE: The information contained here should be used for reference purposes only.

## HOW TO ORDER CUSTOM DRAWING

PTC-15 LH 01 + DRAWING NUMBER (Max. 16 digits)

This way of ordering should be used for options which are not included in the "How to order" standard and optional extras.

## STANDARD OPTIONS

Detents .....	None
Rotor colour .....	Natural
Shaft colour .....	Natural
Wiper position .....	Initial
Torque .....	Standard

## ROTORS

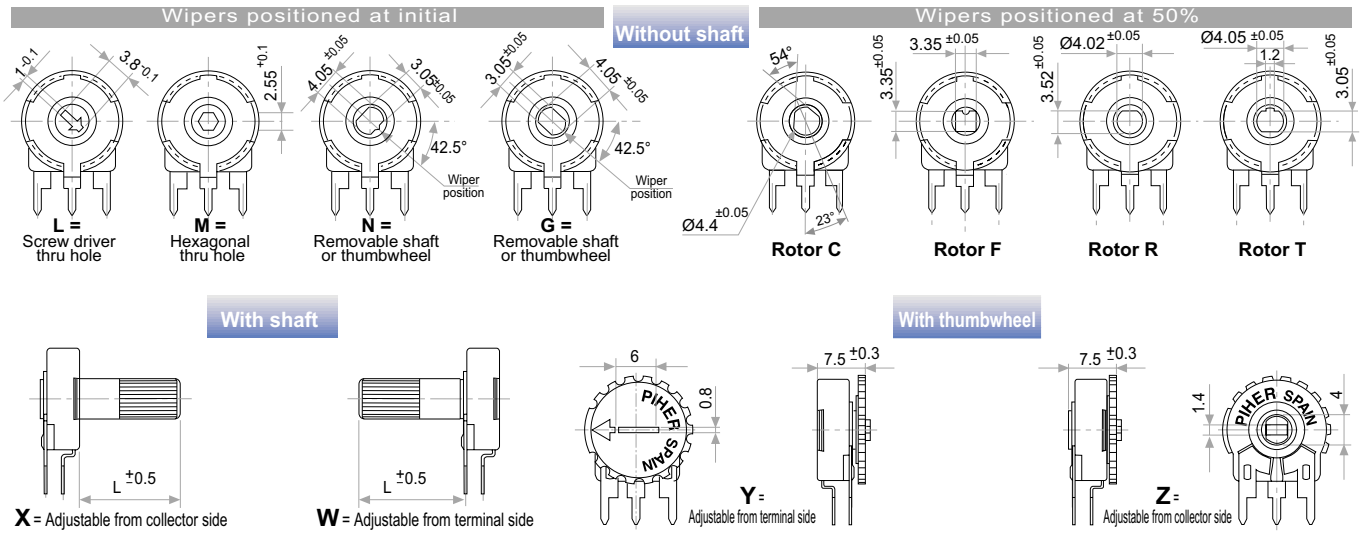

## VERTICAL MOUNTING – HORIZONTAL ADJUSTMENT

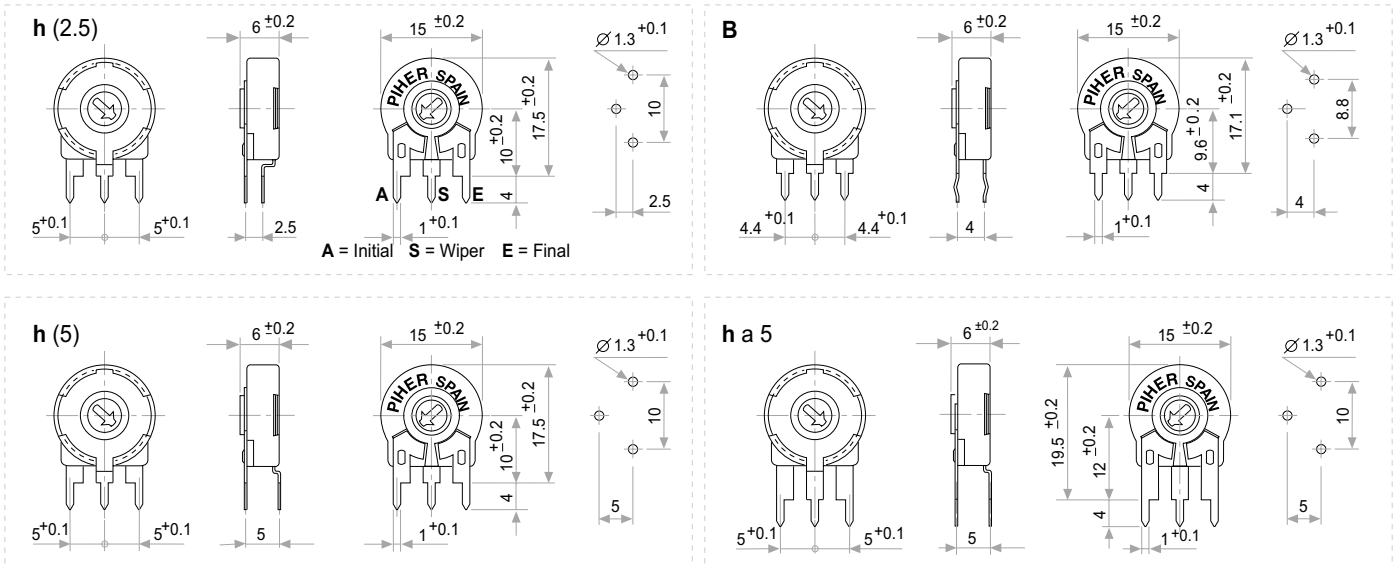

## HORIZONTAL MOUNTING – VERTICAL ADJUSTMENT

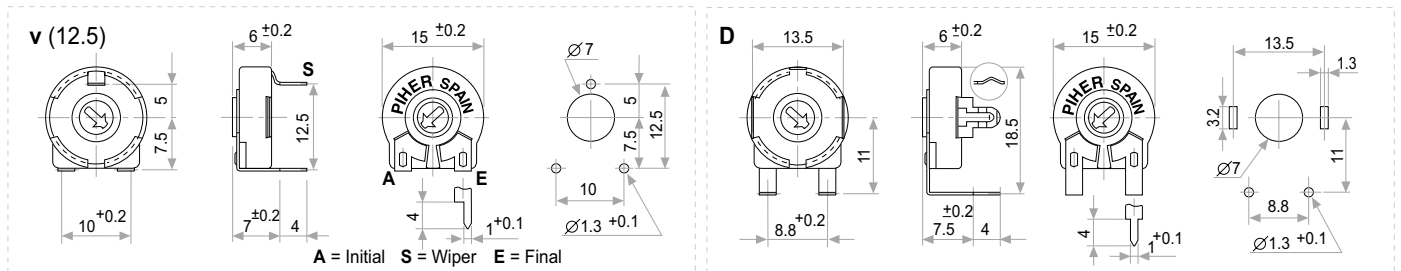

## HORIZONTAL MOUNTING – VERTICAL ADJUSTMENT

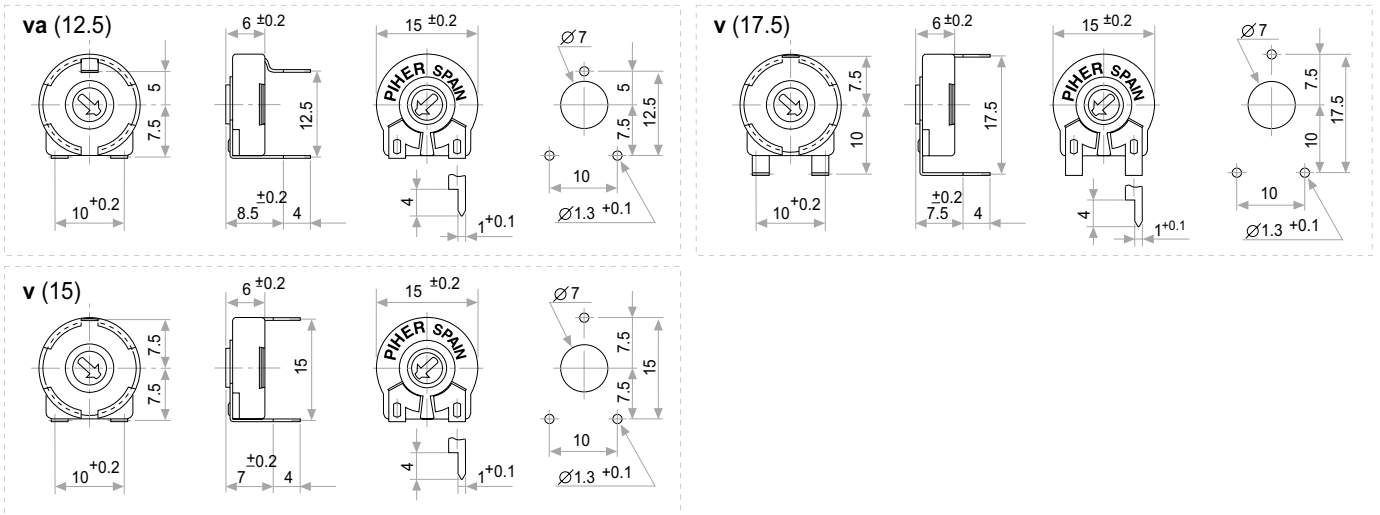

## CRIMPED TERMINALS (DETAIL)

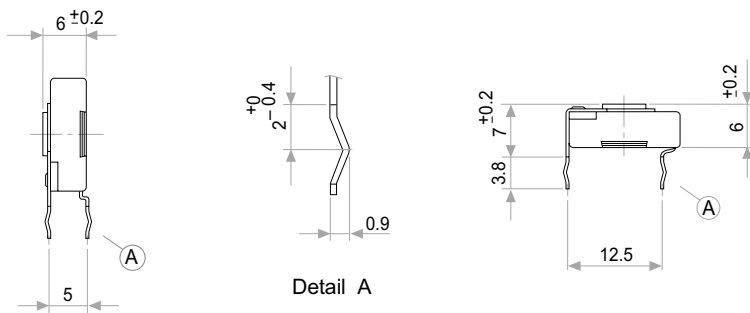

## POWER RATING CURVE

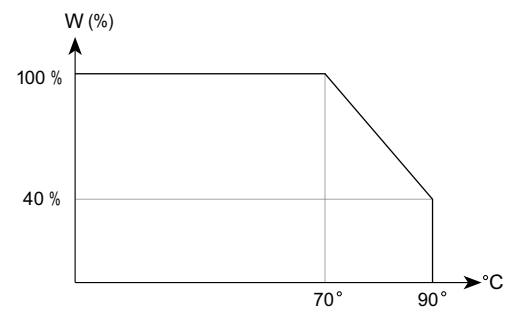

## TAPER

NOTE = Please note relative terminal positions when ordering non linear tapers.

A = Linear  
B = Log.  
C = Alog.

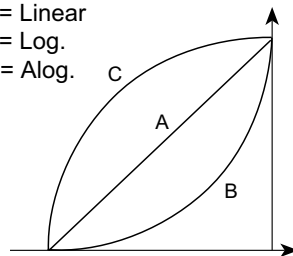

Standard

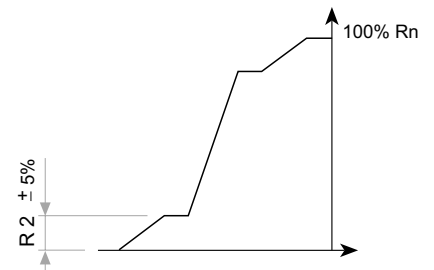

Special curve example

## OPTIONS

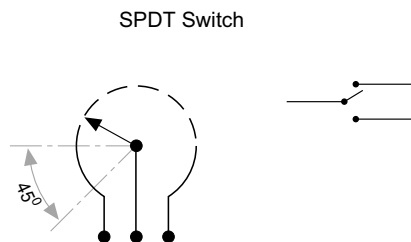

SPDT Switch

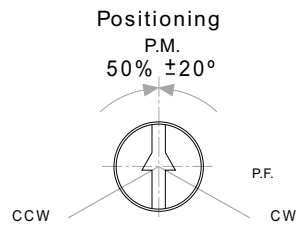

Std. Position = CCW

## TESTS

## TYPICAL VARIATIONS

ELECTRICAL LIFE	1.000 h. @ 70°C; 0.5 W	± 5 %
MECHANICAL LIFE (CYCLES)	100 @ 10 CPM ...15 CPM	± 3 % (Rn < 1 MΩ)
TEMPERATURE COEFFICIENT	-40° C; +90° C	± 100 ppm (Rn <100 K)
THERMAL CYCLING	16 h. @ 90° C; 2h. @ -40° C	± 2.5 %
DAMP HEAT	500 h. @ 40° C @ 95% HR	± 5 %
VIBRATION (for each plane X,Y,Z)	2 h. @ 10 Hz. ... 55 Hz.	± 2 %

NOTE: Out of range values may not comply these results.

## PACKAGING

MODEL	PIECES / BOX
No thumbwheel / shaft	200 (40 x 85 x 185 mm.)
With thumbwheel / shaft up to 19 mm.	100 (40 x 85 x 185 mm.)
With shaft exceeding 19 mm.	50 (40 x 85 x 185 mm.)

## SHAFTS

### Hollow model shafts

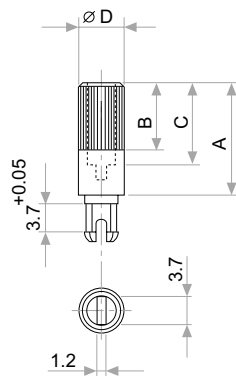

A = Length (FRS)  
 B = Knurling length  
 C = Hollow depth  
 D = Shaft diameter  
 FRS = From rotor surface

FIG.	A	B	C	D	Ref.
1	12	9	8	6	5272
2	19	9	15	6	5214
5	9.5	6.5	5.5	6	5208
9	35	9	15	6	5216
10	37.8	9	33.8	6	5218
11	35	25	15	6	5209
13	7.8	4.8	3.8	6	5265

### Solid model shafts

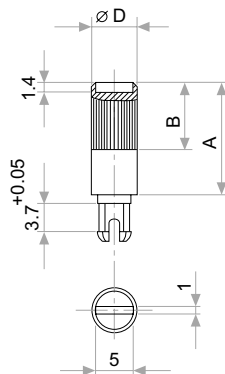

FIG.	A	B	D	Ref.
6	15	9	6	5219
7	16.8	9	6	5220
8	25.3	9	6	5207
12	46	5	6	5227

Slot (1 x 1.4) perpendicular to wiper position. Fig. 12 slot is on line with wiper position.

# SHAFTS

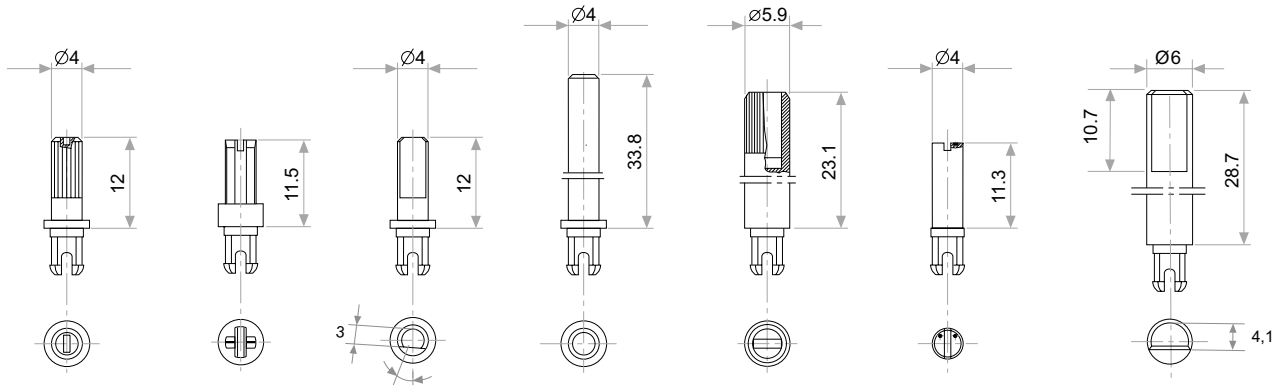

Fig. 3 / Ref. 5372    Fig. 14 / Ref. 5248    Fig. 15 / Ref. 5217    Fig. 16 / Ref. 5262\*    Fig. 17 / Ref. 5210    Fig. 18 / Ref. 5271    Fig. 19 / Ref. 6032\*

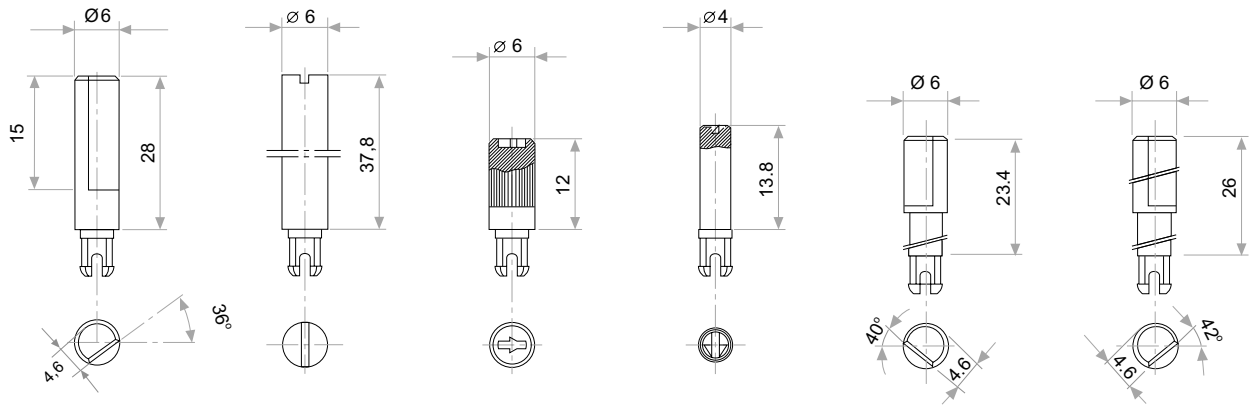

Fig. 20 / Ref. 5369\*    Fig. 21 / Ref. 6031\*    Fig. 22 / Ref. 6029    Fig. 23 / Ref. 6022    Fig. 24 / Ref. 6058    Fig. 25 / Ref. 6059

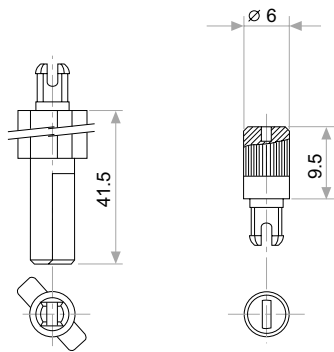

Fig. 27 / Ref. 5268\*    Fig. 28 / Ref. 6055

\* Not available in self extinguishable plastic

# THUMBWHEEL

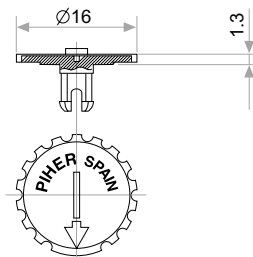

Fig. 4 / Ref. 5371